

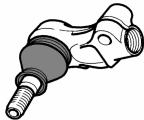

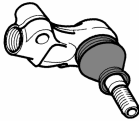

SAAB

9-3 (YS3D) 2,0i/2,0Turbo/2,0SE Turbo/2,3i/2,3iTurbo 2,2TiD	Ltr. 2,0/2,3 2,2D	Baujahr Year 02/1998 - 09/2002
9-3 CABRIO (YS3D) 2,0i/2,0Turbo/2,0SE Turbo/2,3i/2,3iTurbo	2,0/2,3	02/1998 - 09/2002

VERGLEICHS-NR. CROSS-REF.-NO.	HEYD-NR.	BENENNUNG / ABMESSUNG DESCRIPTION / DIMENSION	EINBAU POSITION	BILD FIGURE
42 42 749 324 055	P 15.76	Spurstangengel. Innengew. Tie rod end, internal thread M16x2,0 LH	L ⇐	
42 42 756 324 056	P 15.77	Spurstangengel. Innengew. Tie rod end, internal thread M16x2,0 RH	R ⇐	
322 575	P 13.81	Einstellbolzen Adjustment bolt M16x1,5 L+R	L+R ⇐ ⇐	
42 42 673 322 147 322 079	P 15.57	Gelenkstange Ball joint rod M16x2,0 RH	L ⇐ ⇐	
42 42 681 322 146 322 080	P 15.56	Gelenkstange Ball joint rod M16x2,0 RH	R ⇐ ⇐	
45 44 599 350 263	P 15.43	Koppelstange, Vorderachse Stabiilizer link, front axle	L+R ⇐⇐ 	

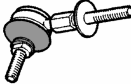

SAAB

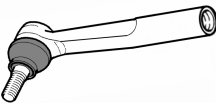
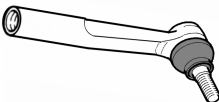
9-3 (YS3F) 1,8i/1,8t/2,0t/2,0T/2,8Turbo V6 1,9TiD/1,9TTiD/2,2TiD	Ltr. 1,8/2,0/2,8 1,9D/2,2D	Baujahr Year 09/2002 -
9-3 CABRIO (YS3F) 1,8t/2,0t/2,0T/2,8Turbo V6 1,9TiD/1,9TTiD	1,8/2,0 1,9D	08/2003 -
9-3 COMBI 1,8i/2,0t/2,0T/2,8Turbo V6 1,9TiD/1,9TTiD	1,8/2,0/2,8 1,9D	03/2005 -

VERGLEICHS-NR. CROSS-REF.-NO.	HEYD-NR.	BENENNUNG / ABMESSUNG DESCRIPTION / DIMENSION	EINBAU POSITION	BILD FIGURE
52 39 314 52 35 650 1 603 227	P 08.71	Spurstangengel. Innengew. Tie rod end, internal thread M14x1,5 RH	L ⇐	
52 39 322 52 35 668 1 603 228	P 08.72	Spurstangengel. Innengew. Tie rod end, internal thread M14x1,5 RH	R ⇐	

SAAB

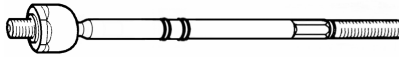
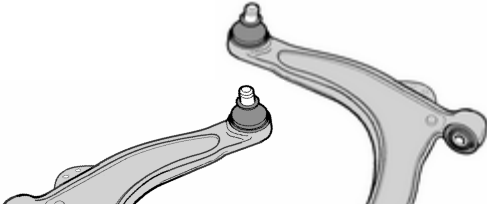
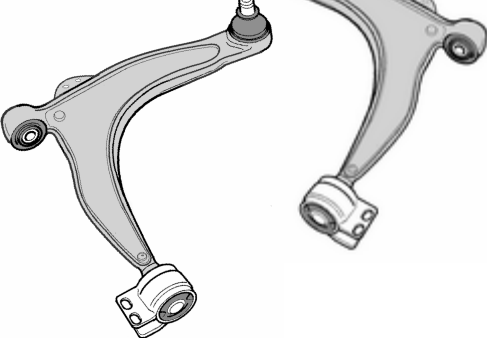
9-3 (YS3F) 1,8i/1,8t/2,0t/2,0T/2,8Turbo V6 1,9TiD/1,9TTiD/2,2TiD	Ltr. 1,8/2,0/2,8 1,9D/2,2D	Baujahr Year 09/2002 -
9-3 CABRIO (YS3F) 1,8t/2,0t/2,0T/2,8Turbo V6 1,9TiD/1,9TTiD	1,8/2,0 1,9D	08/2003 -
9-3 COMBI 1,8i/2,0t/2,0T/2,8Turbo V6 1,9TiD/1,9TTiD	1,8/2,0/2,8 1,9D	03/2005 -

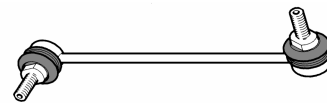
VERGLEICHS-NR. CROSS-REF.-NO.	HEYD-NR.	BENENNUNG / ABMESSUNG DESCRIPTION / DIMENSION	EINBAU POSITION	BILD FIGURE
93 175 520 1 603 244	P 08.73	Axialgelenk Axial joint M14X1,5 RH	L+R ⇔ ⇐	
12 799 199 12 796 013 352 051	P 08.91	Querlenker mit Gummilager Control arm with bushing Vorderachse / front axle	L ↓	
12 799 200 12 796 014 352 052	P 08.92	Querlenker mit Gummilager Control arm with bushing Vorderachse / front axle	R ↓	
24 417 251 350 603	P 08.41	Pendelstütze Vorderachse Self-alignment link front axle	L+R ↗↘ 	

SAAB

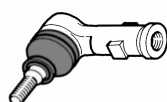
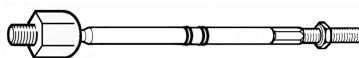

9-5 (YS3E) 2,0/2,0t/2,3t/2,3Turbo 1,9TiD/2,2TiD/3,0TiD	Ltr. 2,0/2,3 1,9D/2,2D/3,0D	Baujahr Year 09/1997 -
9-5 (YS3E) COMBI 2,0/2,0t/2,3t/2,3Turbo/3,0V6t 1,9TiD/2,2TiD/3,0TiD	2,0/2,3/3,0 1,9D/2,2D/3,0D	10/1998 -

VERGLEICHS-NR. CROSS-REF.-NO.	HEYD-NR.	BENENNUNG / ABMESSUNG DESCRIPTION / DIMENSION	EINBAU POSITION	BILD FIGURE
48 36 540 324 063	P 15.78	Spurstangengel. Innengew. Tie rod end, internal thread M14x1,5 RH L= 74 mm	L+R ⇐⇔	
48 36 557 1 603 206	P 15.79	Axialgelenk ZF-Lenkung Axial joint ZF-Steering M14x1,5 RH	L+R ⇔ ⇐	

FORTSETZUNG / CONTINUATION

SAAB

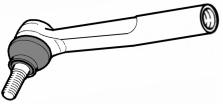
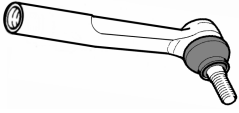
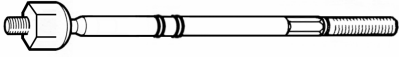
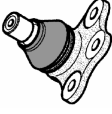
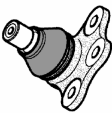
9-5 (YS3E) 2,0/2,0t/2,3t/2,3Turbo 1,9TiD/2,2TiD/3,0TiD	Ltr. 2,0/2,3 1,9D/2,2D/3,0D	Baujahr Year 09/1997 -
9-5 (YS3E) COMBI 2,0/2,0t/2,3t/2,3Turbo/3,0V6t 1,9TiD/2,2TiD/3,0TiD	2,0/2,3/3,0 1,9D/2,2D/3,0D	10/1998 -

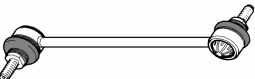
VERGLEICHS-NR. CROSS-REF.-NO.	HEYD-NR.	BENENNUNG / ABMESSUNG DESCRIPTION / DIMENSION	EINBAU POSITION	BILD FIGURE
<i>AB BAUJAHR 10/2001/ FROM YEAR 10/2001</i>				
52 39 314 52 35 650 1 603 227	P 08.71	Spurstangengel. Innengew. Tie rod end, internal thread M14x1,5 RH	L ⇐	
52 39 322 52 35 668 1 603 228	P 08.72	Spurstangengel. Innengew. Tie rod end, internal thread M14x1,5 RH	R ⇒	
52 39 330 52 35 585	SB 04.73	Axialgelenk ZF-Lenkung Axial joint ZF-Steering M14x1,5 RH	L+R ⇔ ⇐	
<i>BIS BAUJAHR 06/2002/ TILL YEAR 06/2002</i>				
52 31 683 48 35 740	SB 04.90	Traggelenk Suspension joint Ø18	L+R ↓	
<i>AB BAUJAHR 07/2002/ FROM YEAR 07/2002</i>				
52 37 516	SB 04.91	Traggelenk Suspension joint Ø20	L+R ↓	
46 86 606 350 610	P 06.43	Pendelstütze Vorderachse Self-alignment link front axle	L+R ↖↗ 	

SAAB

900 I (AC4,AM4) 2,0-16/2,0c/2,0EMS/2,0i/2,0S Turbo/2,1-16	Ltr. 2,0/2,1	Baujahr Year 01/1979 - 12/1993
900 I COMBI / COUPE 2,0-16/2,0c/2,0EMS/2,0i/2,0S Turbo/2,1-16	2,0/2,1	09/1978 - 06/1994
900 I CABRIOLET 2,0-16/2,0S Turbo/2,1-16	2,0/2,1	10/1986 - 06/1994

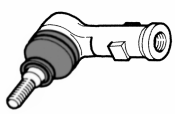
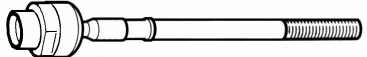
VERGLEICHS-NR. CROSS-REF.-NO.	HEYD-NR.	BENENNUNG / ABMESSUNG DESCRIPTION / DIMENSION	EINBAU POSITION	BILD FIGURE
89 93 560 89 93 354	SB 03.71	Spurstangengel. Innengew. Tie rod end, internal thread M14x2,0 RH	L+R ⇐⇒	
89 88 941	SB 03.73	Axialgelenk Axial joint M14x2,0 RH	L+R ⇔ ⇐	

FORTSETZUNG / CONTINUATION

SAAB

900 I (AC4,AM4) 2,0-16/2,0c/2,0EMS/2,0i/2,0S Turbo/2,1-16	Ltr. 2,0/2,1	Baujahr Year	01/1979 - 12/1993
900 I COMBI / COUPE 2,0-16/2,0c/2,0EMS/2,0i/2,0S Turbo/2,1-16	2,0/2,1		09/1978 - 06/1994
900 I CABRIOLET 2,0-16/2,0S Turbo/2,1-16	2,0/2,1		10/1986 - 06/1994

VERGLEICHS-NR. CROSS-REF.-NO.	HEYD-NR.	BENENNUNG / ABMESSUNG DESCRIPTION / DIMENSION	EINBAU POSITION	BILD FIGURE
<i>AB/FROM MOD. 01/1987</i>				
89 37 088	SB 03.74	Axialgelenk Axial joint M14x2,0 RH	L+R ⇔ ⇐	
89 93 388 89 93 321	SB 03.91	Führungsgelenk Suspension joint	L+R ⇕	

SAAB

900 II 2,0i/2,0.16VTurbo/2,3-16/2,5-24V6	Ltr. 2,0/2,3/2,5	Baujahr Year	07/1993 - 02/1998
900 II COUPE 2,0i/2,0.16VTurbo/2,3-16/2,5-24V6	2,0/2,3/2,5		12/1993 - 02/1998
900 II CABRIOLET 2,0i/2,0.16VTurbo/2,3-16/2,5-24V6	2,0/2,3/2,5		12/1993 - 02/1998

VERGLEICHS-NR. CROSS-REF.-NO.	HEYD-NR.	BENENNUNG / ABMESSUNG DESCRIPTION / DIMENSION	EINBAU POSITION	BILD FIGURE
42 42 749 324 055	P 15.76.	Spurstangengel. Innengew. Tie rod end, internal thread M16x2,0 LH	L ⇐	
42 42 756 324 056	P 15.77	Spurstangengel. Innengew. Tie rod end, internal thread M16x2,0 RH	R ⇐	
42 42 673 322 147	P 15.57	Gelenkstange Ball joint rod M16x2,0 RH	L ⇐ ⇐	
42 42 681 322 146	P 15.56	Gelenkstange Ball joint rod M16x2,0 RH	R ⇐ ⇐	
1 603 167	P 15.91	Traggelenk Suspension joint	L+R ⇓	
45 44 599 350 263	P 15.43	Pendelstütze Vorderachse Self-alignment link front axle	L+R ⇐⇓ 	

SAAB

9000 **SCHRÄGHECK**
2,0-16/CS/ND Turbo/2,0-16Turbo/Turbo CS
2,3-16CD/CSE/CSE Eco Power/2,3-16Turbo/CSE
9000
2,0-16/CD/Turbo/Turbo CD/
2,3-16CD/Turbo/CDE/CDE Eco Power

Ltr. 2,0
2,3

Baujahr 09/1984 - 12/1998
Year

2,0
2,3

04/1985 - 12/1998

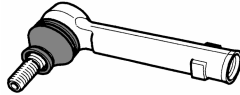
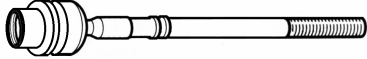
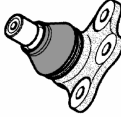
VERGLEICHS-NR. CROSS-REF.-NO.	HEYD-NR.	BENENNUNG / ABMESSUNG DESCRIPTION / DIMENSION	EINBAU POSITION	BILD FIGURE
89 93 453	SB 03.72	Spurstangengel. Innengew. Tie rod end, internal thread M14x1,5 RH L=1 42 mm	L+R ↔⇒	
89 62 250	SB 03.75	Axialgelenk Axial joint M14x1,5 RH L= 322 mm	L+R ⇒ ↔	
89 72 135 89 57 045	SB 03.92	Traggelenk Suspension joint	L+R ↓	
89 52 944	SB 03.41	Pendelstütze Vorderachse Self-alignment link front axle	L+R ↖↗ 